

INSTALLATION INSTRUCTIONS for Replacement Ice Maker D7824706QCM

4020143

This Kit Contains:

- Ice Maker
- Instruction Sheet

For Best Service

- Ensure freezer is set to 10° F. Ice Maker won't add water or cycle until it is 10° F
- Water pressure must be within 15psi to 125psi
- To ensure even sized cubes, ensure the ice maker is installed level
- Throw away the first 2 or 3 trays of ice, this will make sure that any stagnant water from the water lines is clear.



Disconnect power before servicing. Failure to do so can result in death or electrical shock.

IMPORTANT

If you are not replacing an existing Ice Maker, you need a different installation kit. Please see your dealer for the correct kit.

Instructions

1. Remove defective icemaker from the freezer. Unplug Harness, check existing harness to this kit to make sure you have the correct wiring harness. If you do not have the correct harness, you will need a different ice maker kit. Please contact your dealer for the correct ice maker kit.
2. This ice maker has a universal fill cup. Compare this ice maker to the old icemaker to see which prescored cutout that you will need to remove.

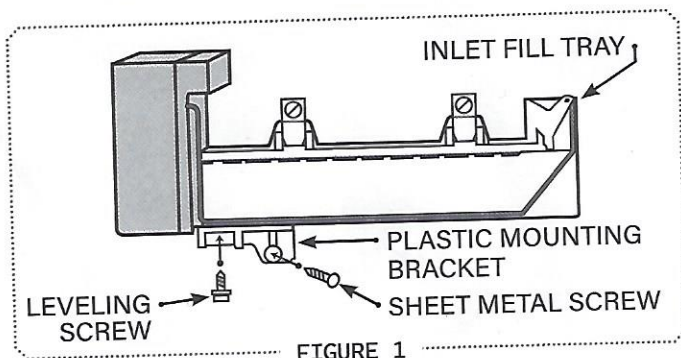

FIGURE 1

3. Using a sharp knife remove the prescored cutout that matches your old ice maker.
4. Plug in existing cable to ice maker head or use the cable provided with the kit. Plug the other end of the cable into the existing plug in the refrigerator.
5. Mount the ice maker in the same mounts as your old ice maker. Make sure to level the ice maker for even size ice cubes. Restore power and turn on water.

Frequently Asked Questions

Question: I plugged in the Ice Maker and nothing is happening.

1. Make sure your water is turned on.
2. Make sure the refrigerator is plugged in.
3. The temperature in the freezer must be 10°F or colder. The icemaker must be allowed to cool to 10°F. About 5 minutes after the icemaker reaches 10°F the ice maker will "wake up" and put water in the ice tray. No water will come in until the icemaker is 10°F or colder.

Question: Do I need to adjust the water level in the icemaker?

1. No, the water level adjustment is preset for this replacement icemaker.

Question: My ice tastes funny, what's going on?

1. Stagnant water in the lines can cause this. If the ice maker has been out of service for awhile, the water in the supply line can be stagnant. Throw away the first three or four trays of ice to get rid of the stagnant taste.

THIS PROCEDURE IS FOR SERVICE TECHNICIANS ONLY

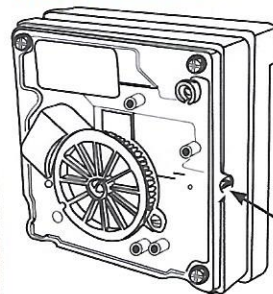

FIGURE 2

To remove cover, pull straight forward. When facing the level adjustment screw make a 1/2 turn clockwise to decrease the water flow by 20 cc's. Turning counter-clockwise to increase water flow.

LEVEL ADJUSTMENT SCREW